

Vertical Mast Lift Specification

01	Manufacturer		HANGCHA GROUP CO.,LTD.
02	Model		HV110D
03	Maxi.working height	m	11.22
04	Maxi.platform height	m	9.22
05	Up and over height	m	7.89
06	Horizontal extension distance	m	3
07	Jib movement	°	+70 /-60
08	Turret rotation	°	345
09	Capacity	kg	210
10	Maximum number of workers		2/1
11	Platform dimensions	m	0.93*0.65
12	Width	m	1
13	Length	m	2.65
14	Height	m	2
15	Turning radius(inside)	m	0.23
16	Turning radius(outside)	m	1.65
17	Ground distance	m	0.06
18	Wheelbase	m	1.22
19	Maxi. Travelling speed	km/h	4.5
20	Mini. Travelling speed	km/h	0.5
21	Maxi slop rating	%	25
22	Maximum allowable inclination	°	2.5
23	Tyre	mm	381*127
24	Weight	kg	2930
25	Charger	V/A	24/30
26	Battery	V/ah	24/240

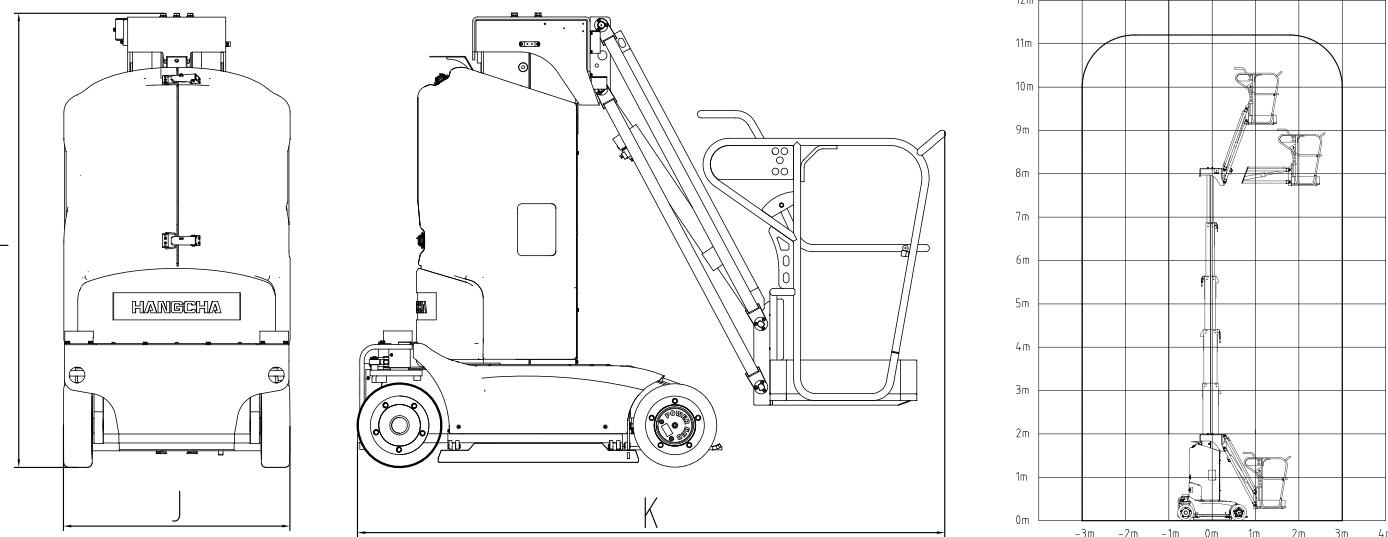

Hangcha Europe GmbH

Mariechen-Graulich-Straße 12a,
65439 Flörsheim am Main,
Germany

Administration
Tel: 0049-61453769188
E-mail: admin@hangchaeurope.com

Ansprechpartner für Arbeitsbühnen
Alfred Müller
Mob:0049-15142453607
E-mail:alfred.mueller@hangchaeurope.com

Technical Support
Thomas Pannke
Mob: 0049-01759284213
E-mail: thomas.pannke@hangchaeurope.com

www.hangchaeurope.com



HANGCHA Group Co., LTD behält sich das Recht vor, Änderungen bezgl. Farbe, Spezifikationen, Ausstattung und sonstige Details, dieser Broschüre ohne Vorankündigung vorzunehmen. Fahrzeugfarben können von den Farben in dieser Broschüre abweichen.



Vertical Mast Lift

The World of Hangcha
SINCE 1956



Vertical Mast Lift

The HANGCHA HV110D is a jib machine that offers outreach capability to get virtually any job done. A 130° rotating jib and 345° non-continuous hydraulic turntable allows for exceptional range of motion and precise positioning. These capabilities combined with the efficient electric drive motors and a low machine weight make the HANGCHA HV110D lift the solution for hard-to-reach jobsite needs.

It has the characteristics of compact body size, small turning radius, good handling performance and strong endurance. It is mainly used in warehouse, exhibition hall, aircraft maintenance, mechanical equipment installation, equipment maintenance and other fields.



Anti-overturning system

/ When the machine raises, this system will open automatically, to protect the machine from overturning while walking at un-leveling ground.

Safety

/ Alloy steel axis, to make sure the safety, reliable and efficient.

Internal charger

/ You can charge the battery directly, do not need to remove it from machine.

The working scope

/ It can go to the working area rapidly trough lifting, lowering, travelling forward and backward, turret turning, etc.

Self-leveling sensor

/ When the degree is more than 2.5°, it will alarm.

The proportional control system

/ Control the speed of traveling, lifting and turret turning as you need.

The turning radius

/ It can work in a very compact area.

LED display

/ Easy for troubleshooting.



CAN BUS control system

/ The machine is equipped with CAN BUS control system, it makes the electrical system simple, reliable, easy maintenance and troubleshooting.



Options

/ Basket socket device
/ Work lamp
/ Anti-collision sensor

Standard Specification

/ The proportional joystick
/ The anti-overturning system
/ Easy access
/ Self-propelled
/ No marking tyre
/ 4X2 drive
/ Automatic break
/ Emergency lower system
/ Flashing light
/ Emergency stop system
/ Explosion proof valve
/ Fault diagnosis
/ Self-leveling sensor
/ 345°non-continuous turret turning
/ Buzzar
/ Horn
/ Swing cover

